



AH-LMB-KIT-INST-2 54|98 Base

Assembly Instructions for Installation



AH-LUMBER-KIT Bill of Material:

| Item | Item Number | Description | Qty |
|------|-----------------|--|-----|
| 1 | AH-150-2 | Bolts and Washers Kit for Mounting Hutch | 1 |
| 2 | AH-LUMBER-002-1 | Zip Ties | 2 |
| 3 | AH-LUMBER-001-1 | Side, 54 98 Base | 2 |

Tools Needed:

1. 15/64" Drill Bit (For Softer Wood) or 1/4" Drill Bit (For Harder Wood)
2. Drill
3. 1/2" Deep Well Socket
4. Ratchet

Installation Instructions:

Step 1: Using 15/64" or 1/4" Drill Bit, drill (8) pilot holes. Repeat for all 4 corners. (See Figure 1)

Figure 1

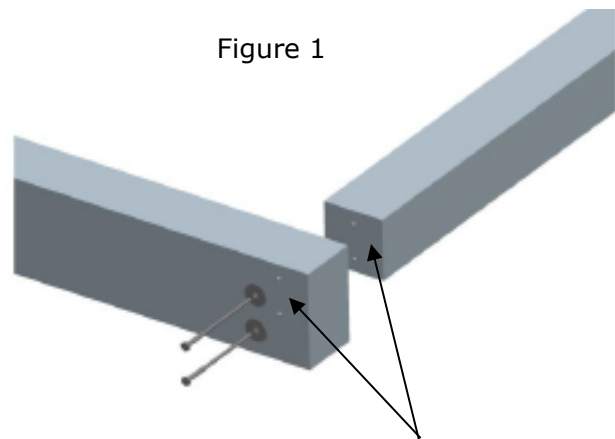

Locate 3/16" Pilot holes at approximate center of



Step 2: Assemble Base: Using 1/2" Deep Well Socket, assemble lumber using (2) 1" washers with (2) 4" x 5/16 Lag Screws. Repeat for all 4 corners (See Figure 1).

Step 2: Assemble Base to Hutch: Using 1/2" Deep Well Socket, washers and screws, fasten (@) brackets near entrance securing Hutch to Base (See Figure 2)

Fasten hutch to base at remaining locations around perimeter using washers and screws.

Figure 2



Entrance Bracket Locations