

Revised October 2021



CT-7000K

Calf-Tel Front Door

Assembly Instructions

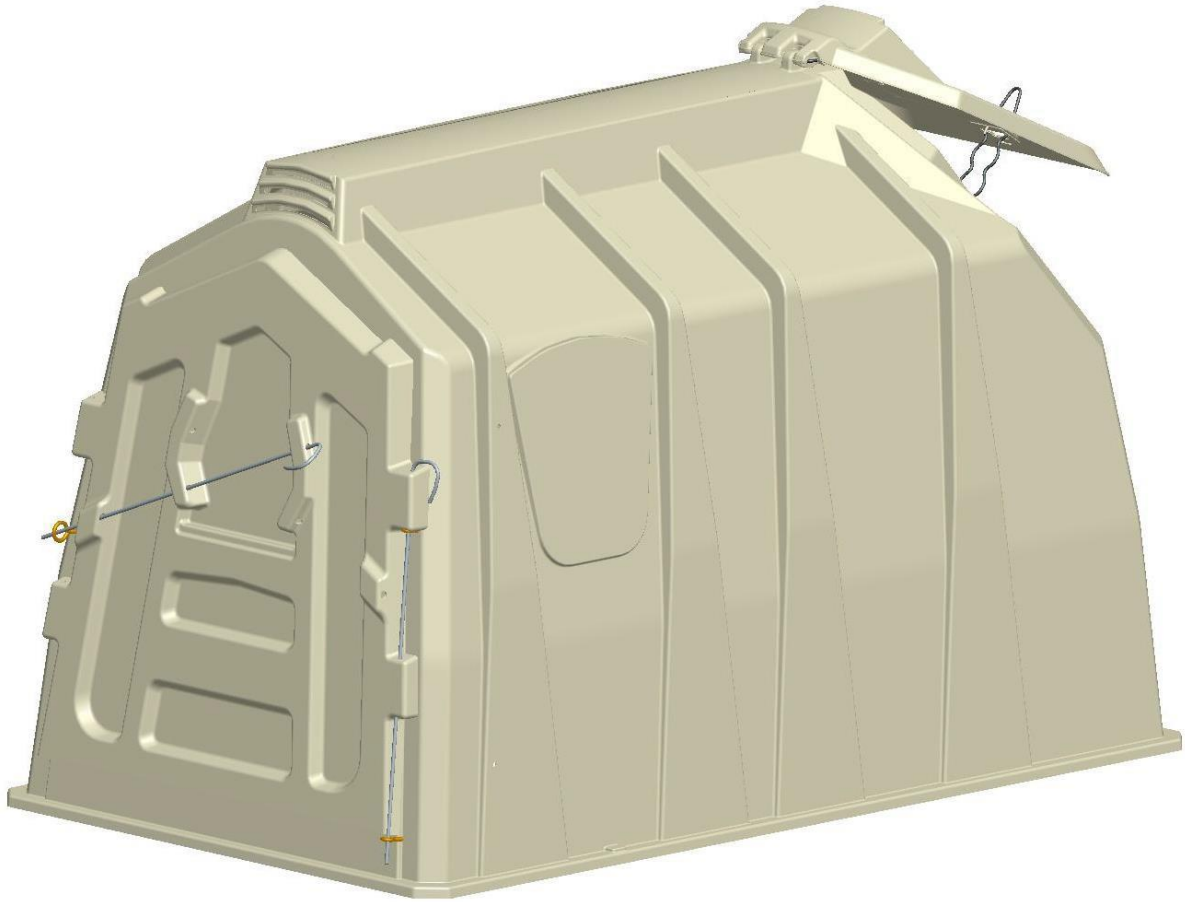



CT-7000 Front Door Bill of Materials:

Item	Item Number	Description	Qty
1	CT-7000	Front Door	1
2	CT-7100	L-Rod	2
3	CT-7150	Large Dia. Eyebolt	1
4	CT-9100	Eyebolt Kit (4 eyebolts w/hardware)	1

Tools Required:

- 1/2" Open End Wrench (2)
- 1/2" Socket and Ratchet

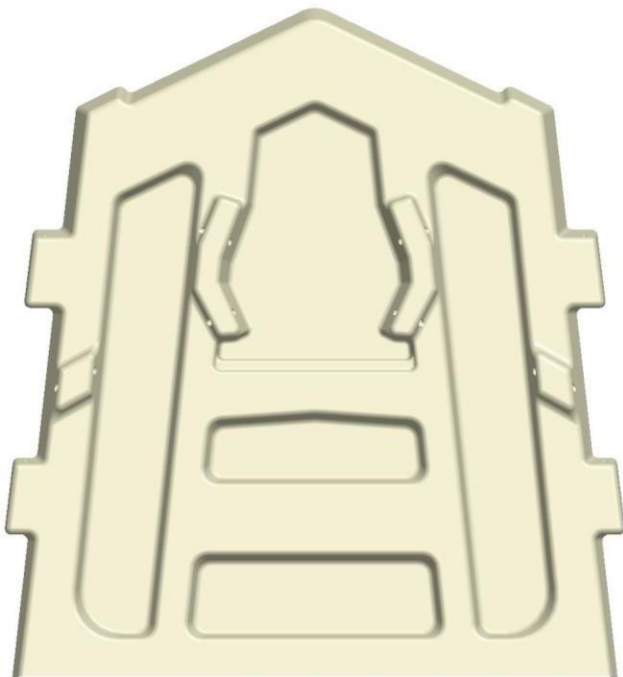

Front Door – 1 per



L-Rod – 2 per



Large Dia. Eyebolt – 1 per



Eyebolts w/Hardware – 4 per



The Calf-Tel Front Door may be installed in multiple configurations, the first set of instructions will guide you through the installation of a door that swings open to the right (as looking at the hutch)...to have a door that swings to the left, apply directions to the opposite side.

The last set of instructions will guide you through the installation of a door that DOES NOT swing.

STEP 1: Drill three (3) holes; 1 1/32" (tight) or 3/8" (loose) diameter, at the below dimensions measured off of the top surface of the bottom perimeter of the Calf-tel.

Holes should be 3/4" in (towards door opening) from the side edge of the front face.

NOTE: The Calf-tel may have dimples in the corresponding locations, use dimples as drill points to drill holes.

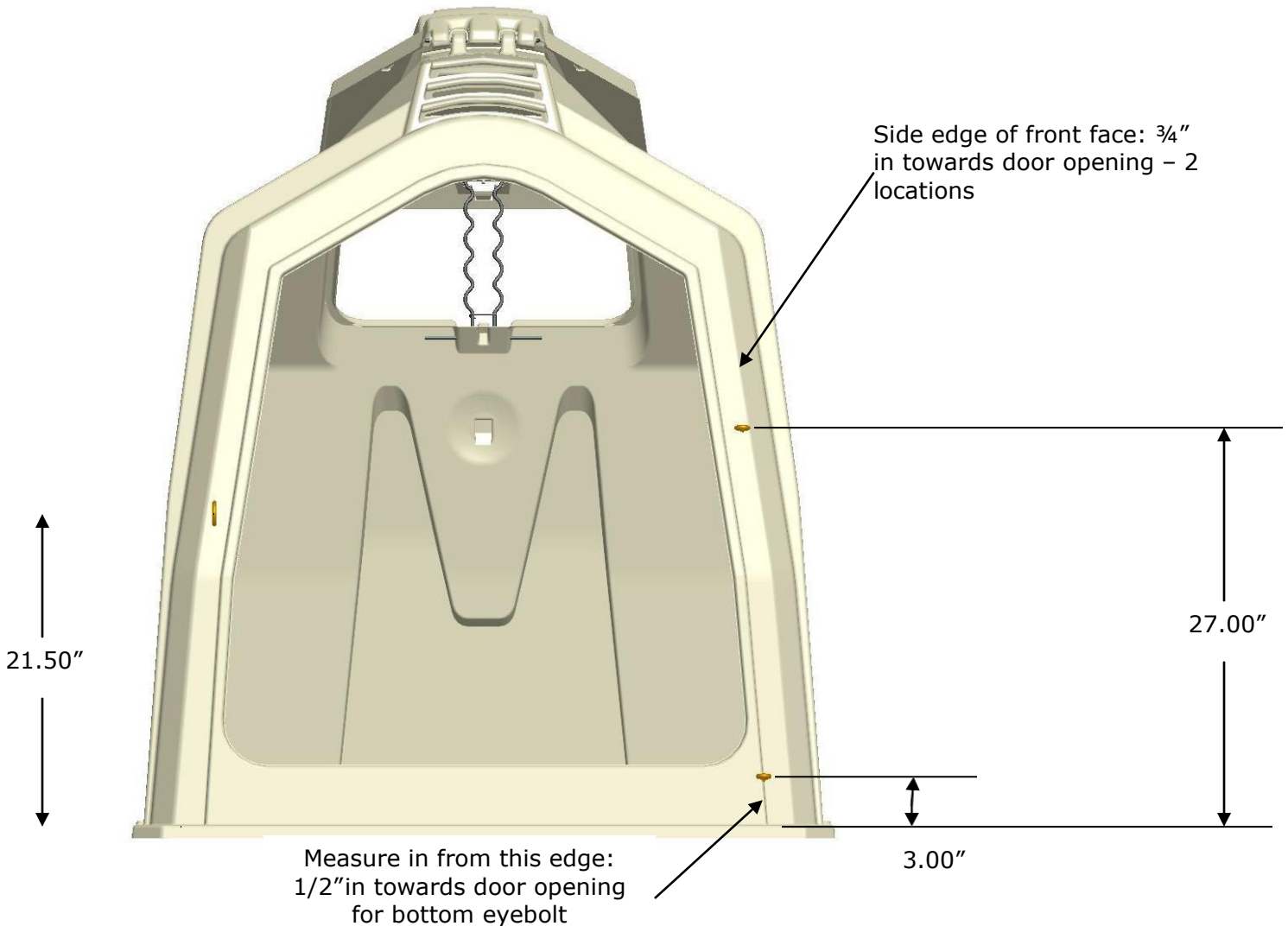



STEP 2: Attach three (3) eyebolts using the eyebolts and hardware supplied.

NOTE: Extend the eyebolts so the center of the eye is approximately 1" out from the surface of the hutch...adjust if necessary to allow the door to swing freely

NOTE: When assembling the Calf-tel Front Door for a left or right swing installation, two (2) smaller eye eyebolts will be left over.

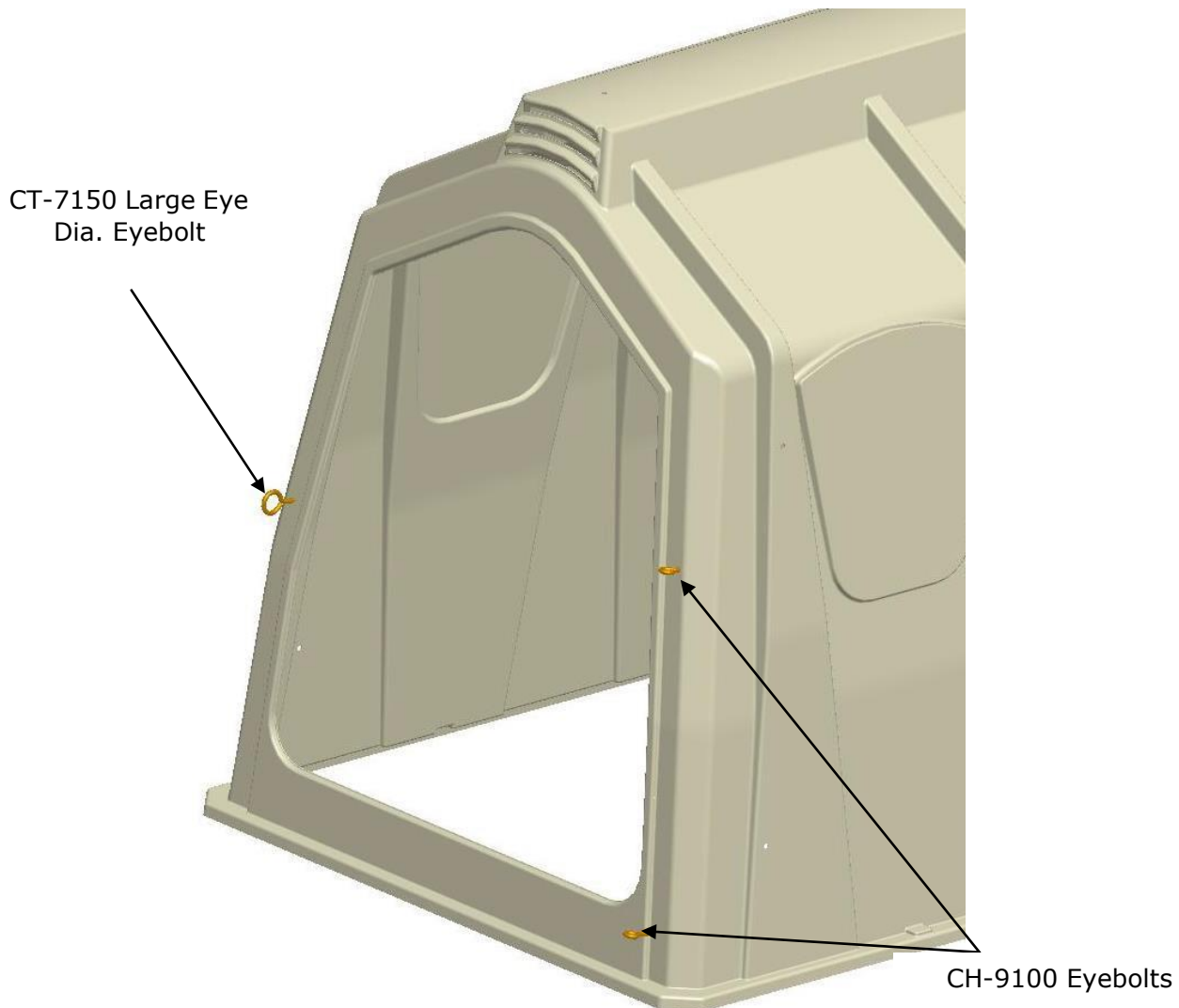



STEP 3: Place the Calf-tel Front Door on the front face of the Calf-tel so the bottom of the knuckles are on the top of the two (2) eyebolts attached in the previous step.

Slide L-Rod through holes in the center of the door that line up with the Large Dia. Eyebolt. This locks the door in place when closed.

Slide L-Rod through holes in knuckles and through the eyebolts. This creates the "hinge" side of the door.

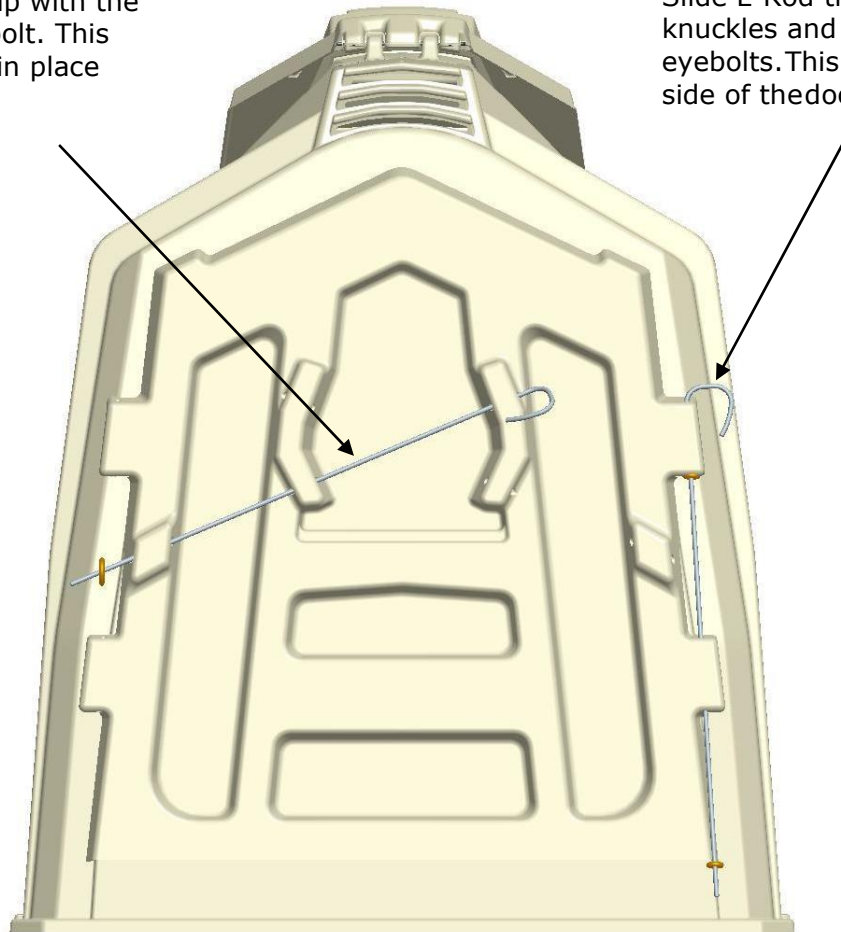



ALTERNATIVE ASSEMBLY METHOD

This set of instructions will guide you through the installation of a door that DOES NOT swing.

STEP 1: Per the instructions in Step 1 above, drill two sets of two (2) holes on both the left and the right side of the front opening of the Calf-tel.

STEP 2: Attach two (2) eyebolts on the left side and two (2) eyebolts on the right side of the front opening.

NOTE: You will have the large eye diameter eyebolt leftover.

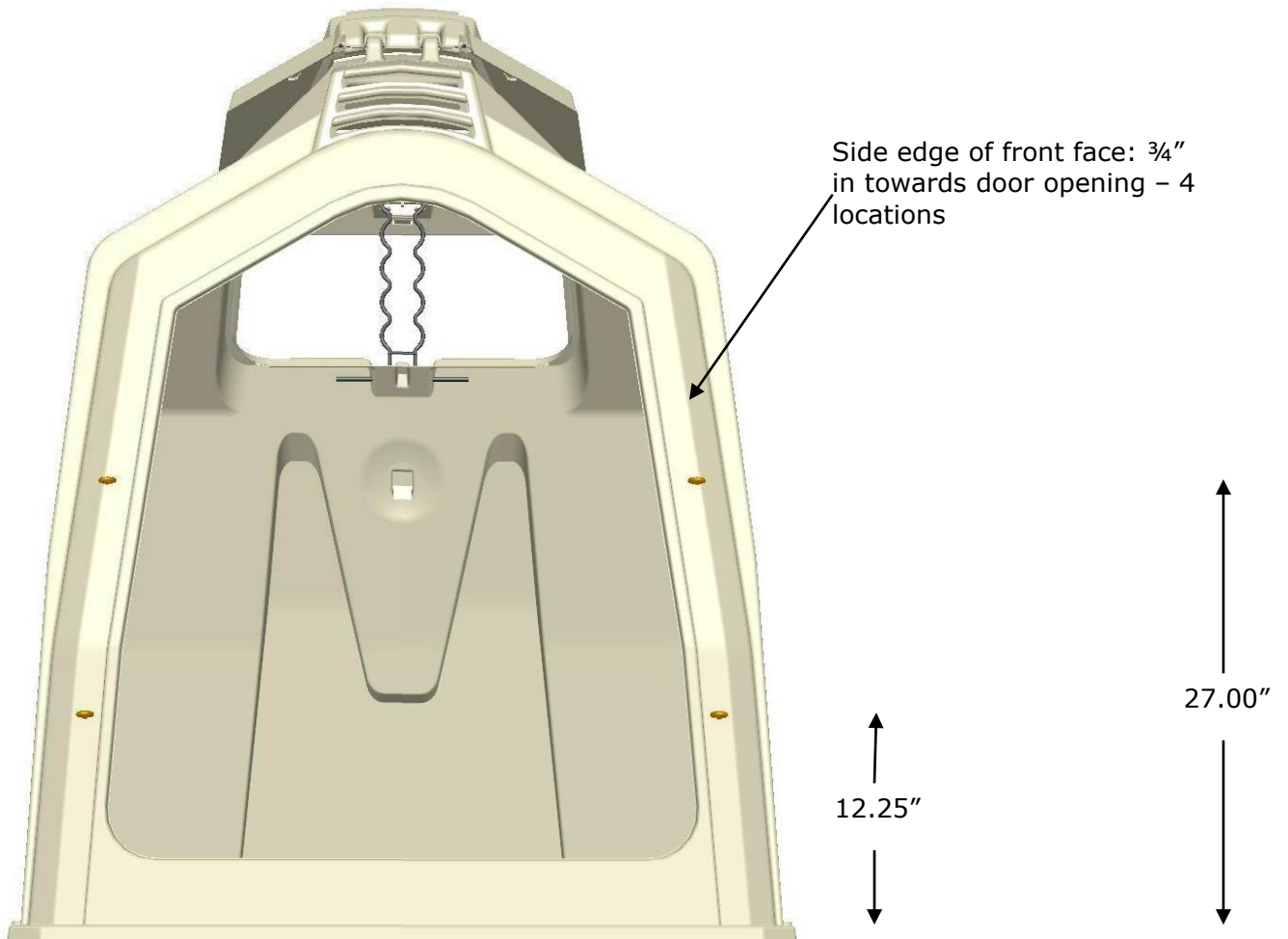



STEP 3: Place the Calf-tel Front Door on the front face of the Calf-tel so the bottom of the knuckles are on the top of the two (2) eyebolts attached in the previous step. Slide L-Rods into place as shown.

Slide L-Rod through holes in knuckles and through the eyebolts.

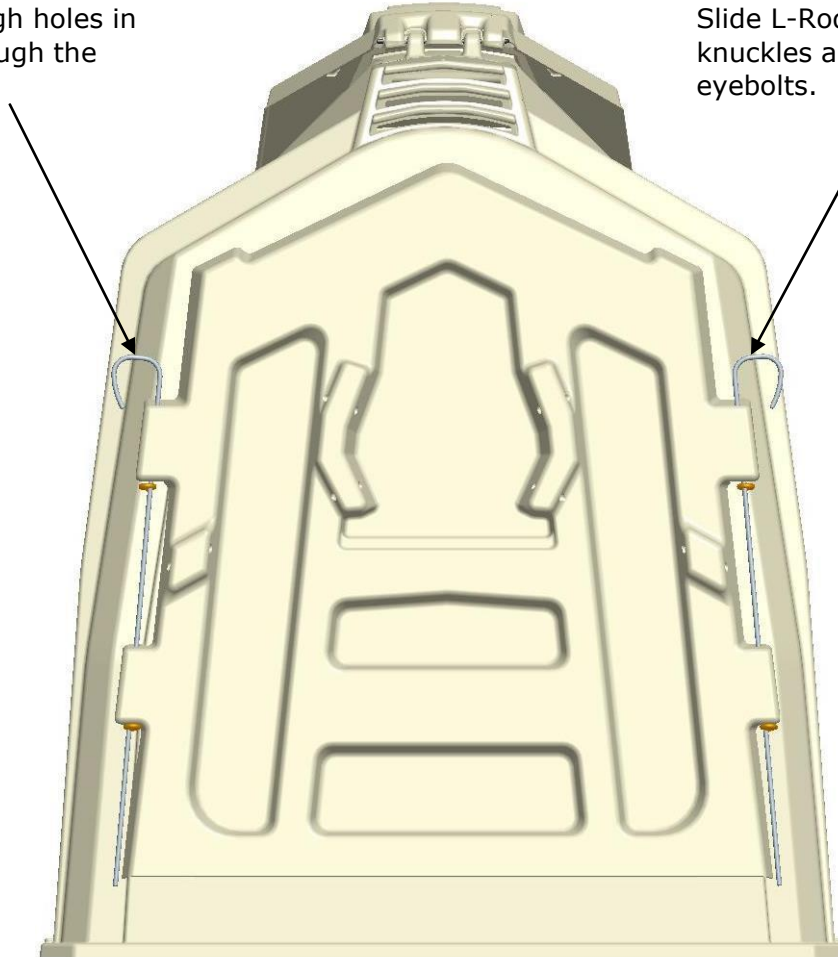

Slide L-Rod through holes in knuckles and through the eyebolts.