

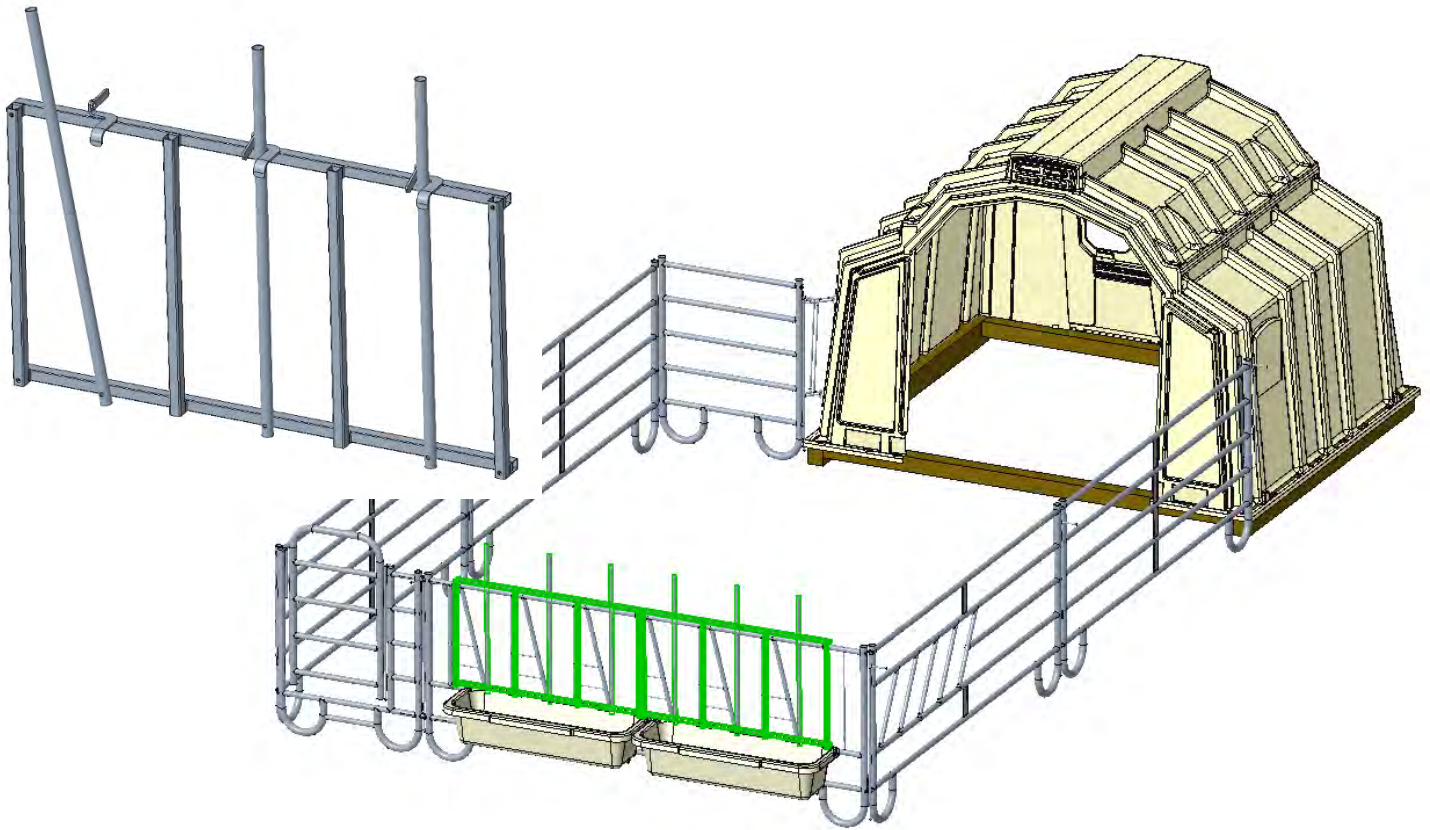

# CTC-1032 Headlock - V Trainer Front For the 54/98 MultiMax Assembly Instructions



**Bill of Material: (plastic hutch not included)**

Item	Item Number	Description	Qty
1	CTC-1032	Headlock for V Trainer Front	2

**Tools Needed:**

1. 1/2 in Socket & Ratchet
2. 1/2 in Open End Wrench
3. 3/8" Drill Bit
4. Drill
5. Rubber Mallet



**Assembly:**

**Step 1:**

- Headlocks are installed on the inside of the V Front – 2 headlock sections are needed to cover all 6 openings.

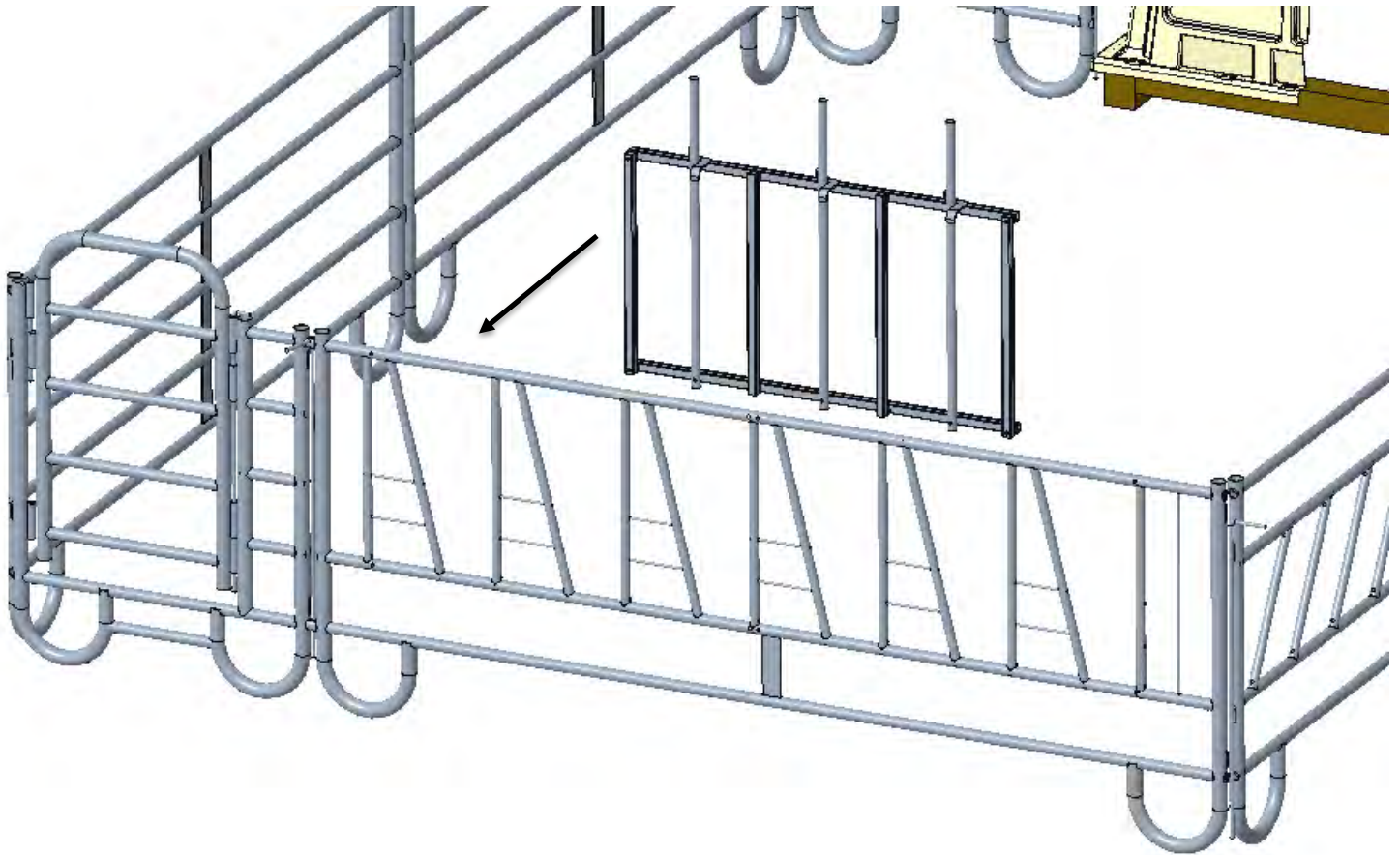



- The headlocks hang on the top horizontal bar

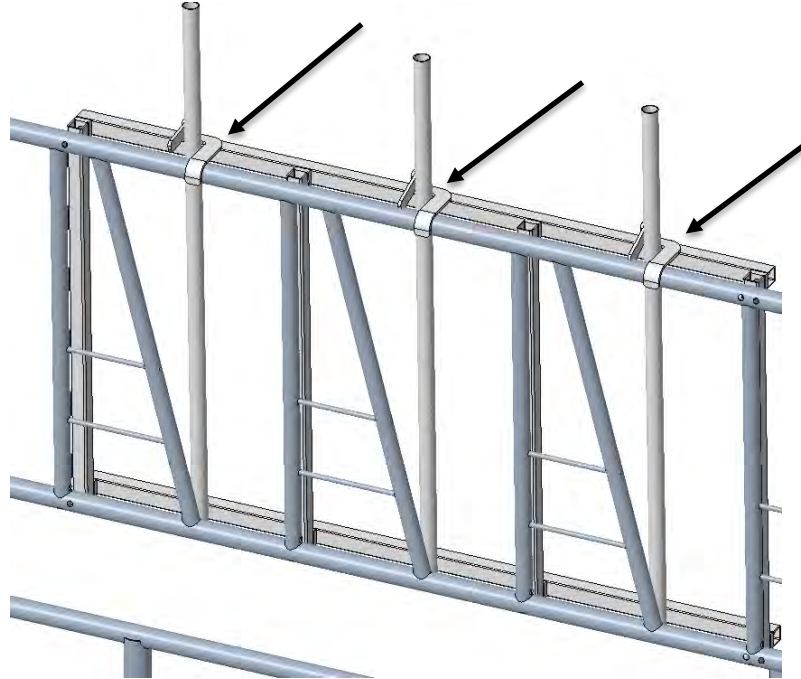

- The headlock is bolted at the 4 corners with the hardware that is shipped in the mounting holes, using the pre-drill holes on the V Front.
  - Lock nut is on the outside of the unit.

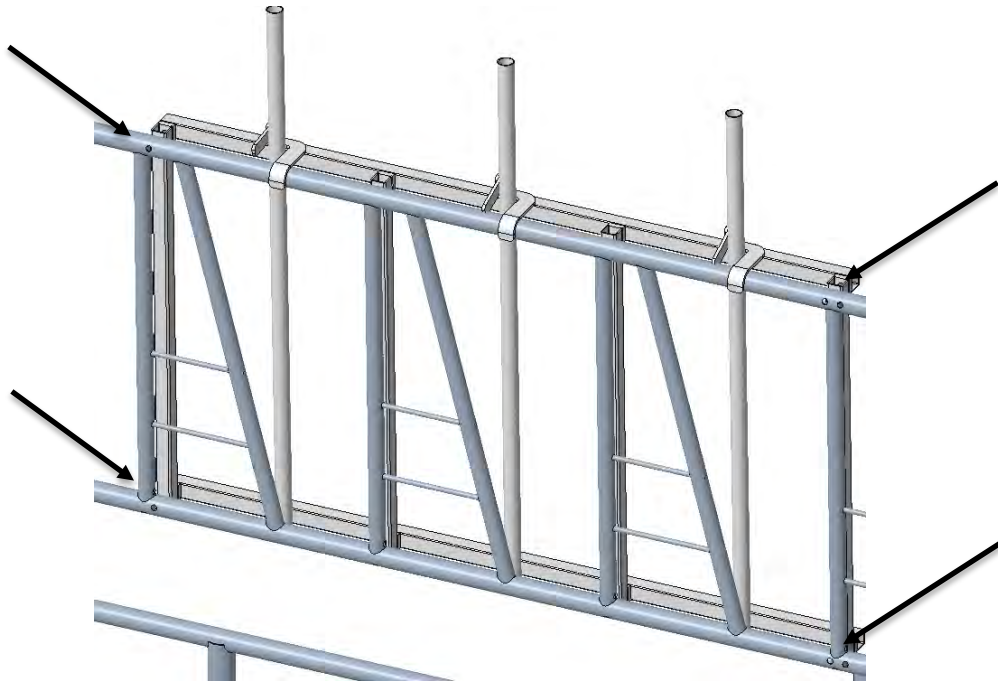





- Repeat installation steps for second headlock

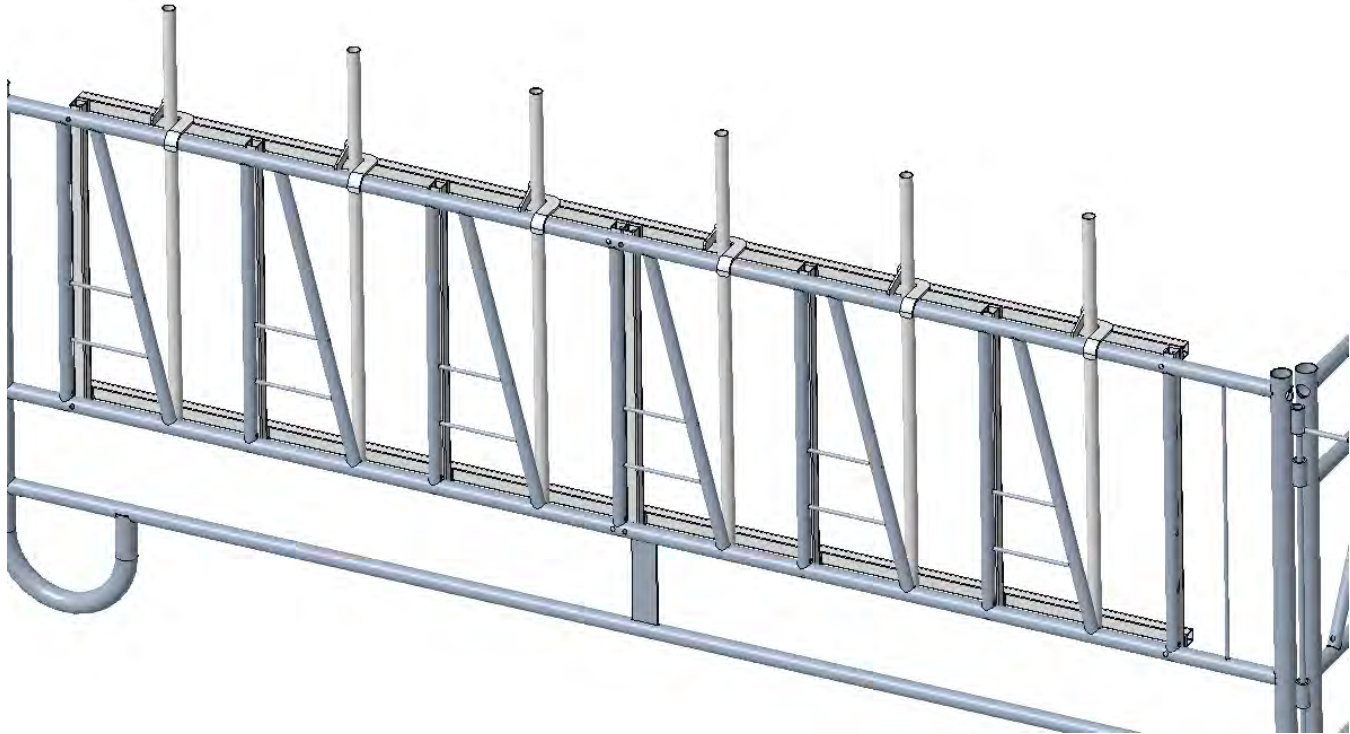

- Hang plastic troughs

